



**PRESSURE SWITCHES
PRESSURE DIFFERENCE SWITCHES
VACUUM SWITCHES**

From 1.5 mbar to 600 bar



MN/MA Pressure Switches

INSTALLATION AND OPERATING INSTRUCTIONS

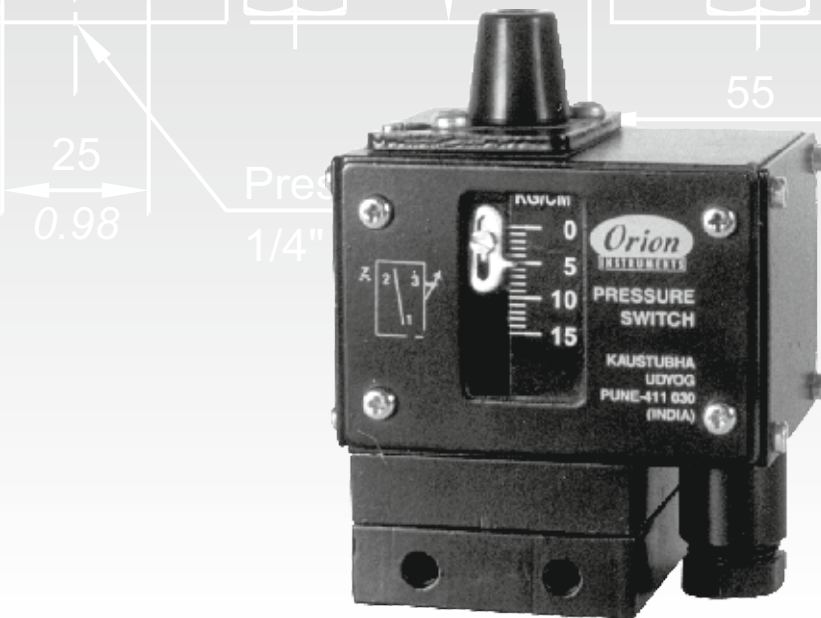

Kaustubha Udyog (Orion Instruments)

S. No. 36/1/1, Sinhgad Road, Vadgaon Khurd, Pune 411 041 INDIA
Tel.: +91-(0) 20-24393877 / 24351592
Telefax : +91-(0) 20-24393577 / 25460486
Email : ku.pressure@gmail.com / info@orion-instruments.io

Certificate No.: FM72815



Website : www.orion-instruments.io

INSTALLATION AND OPERATING INSTRUCTIONS FOR MN/MA MODELS

Construction

The Pressure switch is housed in a diecast aluminium enclosure which conforms to IP54 protection factor. Rubber gaskets can be provided optionally to provide an IP65 enclosure. For calibrated models a scale, visible through a window, is provided. The pressure capsule, at the bottom of the switch, comprises a pressure housing (either of aluminium, brass or SS316), a disc, nylon reinforced rubber diaphragm and a plunger. The electrical changeover is through a snapaction microswitch. The electrical wiring terminates at a terminal strip having screwed ends. A 3/8" cable gland has been provided for cable entry.

Principle of Operation

The pressure in the pressure capsule is converted into force by means of a reinforced rubber diaphragm and a calibrated piston, which is balanced by a compression spring from above. When the force generated by the pressure in the pressure capsule exceeds/falls beyond the balancing spring force, an electrical element is actuated.

Mounting

The high pressure range pressure switches can be mounted in any direction. However, for low range pressure switches it is advised to mount them in such a way that the diaphragm is vertical.

Fig 1A

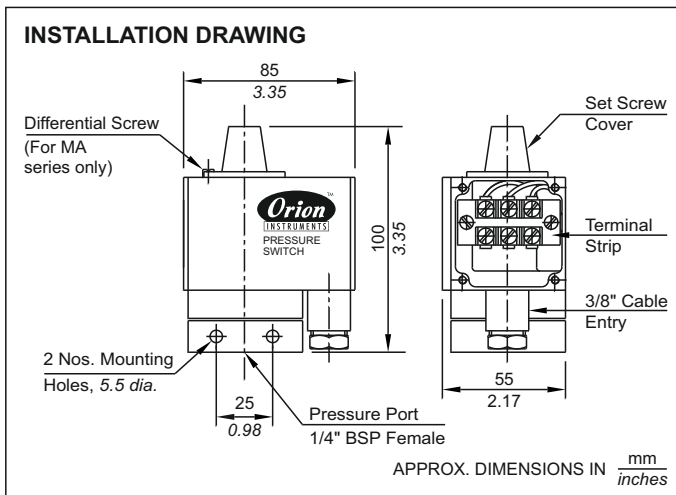
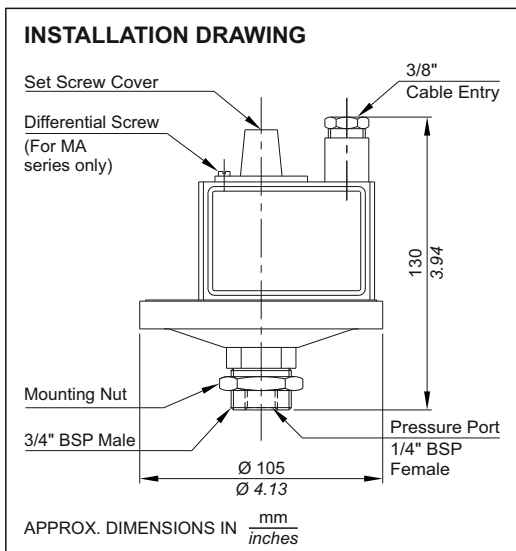

Fig 1B



1) For high range pressure switches

Refer figure 1A

- a) Pressure switches can be mounted directly in case the mounting is rigid.
- b) For panel mounting, use M5 bolts of appropriate length through the mounting holes. If the equipment is subject to vibration, please use rubber washers / pads between the panel and the switch.

2. For low pressure ranges Refer figure 1B

- a) Pressure switches can be mounted directly in case the mounting is rigid.
- b) For panel mounting, use the 3/4" nut provided alongwith the pressure switch, to clamp the switch onto the panel. A hole of dia. 28 mm should be sufficient for the mounting boss to pass through. The panel thickness should not exceed 6 mm.

- 3) Connect the pressure tubing to the pressure port. The pressure port size is generally 1/4" B.S.P. female, unless specially ordered otherwise. Other sizes can be obtained via adaptors.

Electrical Connections

Pressure switches will generally have only one SPDT microswitch.

Pressure switches with two SPDT microswitches can also be provided. For 2 SPDT microswitches, the scale will correspond to one microswitch. The setpoint of the other microswitch can be varied and the on-off differential of the other microswitch will depend on the stage difference between the two setpoints in MN models. For MA models the stage difference will be factory set and cannot be varied.

Wiring

- a) Remove the right hand side (RHS) cover. Refer figure 3.
- b) Pass the cable through the cable gland and connect the wiring as per the wiring diagram. The colour code is as per the details given below.

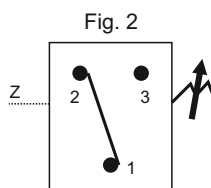

- | | |
|------------------------------|----------|
| terminal 1 (common) | : Red |
| terminal 2 (Normally closed) | : Black |
| terminal 3 (Normally open) | : Yellow |

Set Point Adjustment

For MN MODELS Refer figure 3

- 1) Remove the setscrew cover.
- 2) i) **MN UNCALIBRATED** Models : Turn the setscrew to the extreme negative end.
ii) **MN CALIBRATED** Models : Adjust the desired setpoint on the scale.
- 3) Apply the desired cutin (lower) / cutout (higher) pressure to the pressure switch.
- 4) i) **MN UNCALIBRATED** Models : Increase the pressure setting by turning the set screw till contacts changeover.
ii) **MN CALIBRATED** Models : proceed to Step 5
- 5) Some minor adjustment will be required to achieve the exact cutin (lower) / cutout (higher) point, which can be checked with the help of a proper pressure measurement device.
- 6) Replace the setscrew cover.

Tip : The pressure switches are factory set at half the setpoint range (unless otherwise specified in a Purchase Order). Step 2 can be omitted if the desired set point is more than the factory setting. for MN uncalibrated models

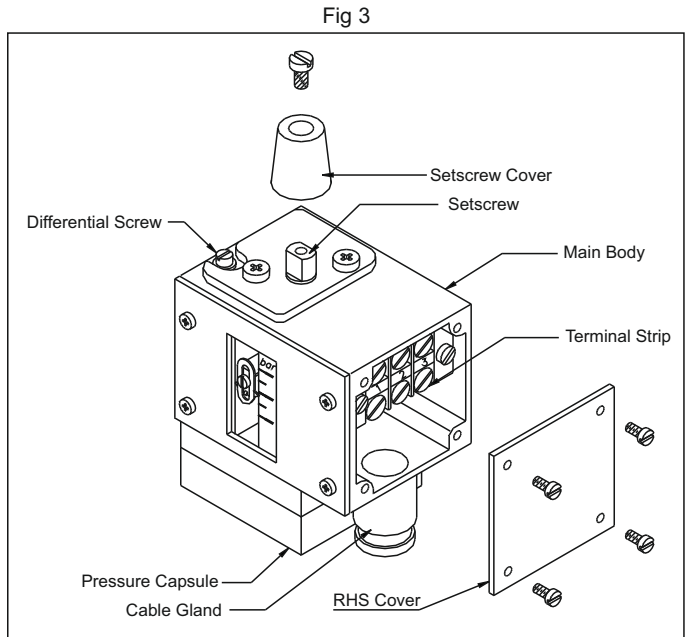

FOR MA MODELS

1. Decide the cut-in (lower) pressure P1 & the cut-out (upper) pressure P2. The differential will be $(P2 - P1)$.
2. Remove the set screw cover.
3. a) For MA UNCALIBRATED models
 - i) Turn the setscrew to the extreme negative end.
 - ii) Turn the differential screw to the extreme negative end.
 - iii) Apply the desired cutin (lower) pressure to the pressure switch.
 - iv) Increase the pressure setting by turning the setscrew till contacts changeover.
- b) For MA CALIBRATED models
 - i) set the cut-in point on the main-scale with the help of the set-screw.
4. Turn the differential screw to the extreme positive end.
5. Apply the desired cutout (higher) pressure to the pressure switch
6. Decrease the differential pressure setting by turning the differential screw till contacts changeover.
7. Some minor adjustment will be required to achieve the exact cutin (lower) / cutout (higher) point, which can be checked with the help of a proper pressure measurement device.
8. Replace the setscrew cover.

Trouble Shooting Tips

Generally no problems are observed if the pressure switch selection, wiring and the setpoint is proper. For a pressure switch selection procedure, please consult our sales office.

For properly selected pressure switches, if following symptoms are observed, the likely causes and remedies are as stated below.

Symptom 1: Switch does not operate

- 1) Wiring may not be correct. Check electrical connections to the pressure switch, if they are as per the wiring diagram.
- 2) Pressure does not reach the pressure port.
 - a) Check if the entry to the pressure capsule is not blocked by frozen process or scales or impurities in the process.
 - i) If this is the case, try freeing the blocked path by a blunt tool in case of scales or impurities.
 - ii) For frozen process, it is advisable to use chemical seals.

DO NOT OPEN THE PRESSURE CAPSULE IN ANY EVENT.

If the cause is none of the above mentioned probabilities, proceed as per the following steps.

- b) Check the system pressure & set point of pressure switch. For use of pressure switch for falling setpoints, system pressure has to be greater than cutin point. For use of pressure switch for rising setpoints, the system pressure may not be reaching / exceeding the cutout point.
 - (i) For MA models turn the differential screw to the extreme negative end.
 - (ii) Use 'T' connection & connect calibrated pressure gauge to the 'T' connection as shown in the figure 4.
 - (iii) Adjust the setpoint such that the system pressure is greater than the cut-out point of the pressure switch.
 - (iv) If the switch still does not operate, remove the pressure switch physically from the system. There should be continuity between terminals 1 & 2. If no continuity is observed, the pressure switch should be returned to the factory.

Symptom 2: Short Wiring

Isolate the switch electrically. Check the continuity between terminals and the screws fitted to the body. If no continuity is observed in between any of the terminals and screws fitted to the body, check the short connection elsewhere in the circuit. If continuity is observed, the wires of the pressure switch have internally touched the body, and the switch should be returned to the factory.

Symptom 3: Leakage

In case leakage is observed, the pressure switch has to be returned to the factory without opening the pressure capsule. Check for the following likely causes and use a new switch taking proper precautions.

- a) System pressure is greater than working pressure : Use an overrange protector or a switch with appropriate maximum working pressure.
- b) Incompatible wetted parts : The working medium may not be compatible with wetted parts, which damages the sealing of the process from working parts. Use a chemical seal for the pressure switch or use proper compatible wetted parts.
- c) Excessive process temperature : Process temperature may exceed maximum allowable temperature, which in turn damages the diaphragms. Use an impulse tubing of proper length for cooling the process temperature. There may be a pressure drop depending on length of the impulse tube used. Adjust the setpoint of the pressure switch accordingly.

Symptom 4: Chattering

- 1) Check the system pressure for surges. Chattering is observed where the system pressure is close to the cutin / cutout point and the surge pressure exceeds the on-off differential. Use a pressure switch with an adjustable differential or use surge dampers in your system.
- 2) If there is a relay in the circuit, check if the relay is properly plugged in. Chattering may be due to loose contacts. ■

Fig 4

